

## INTERNATIONAL DYNETICS 520 CONTAINER PACKERS CONTAINER PACKERS FOR HI RISE BUILDINGS

### GENERAL DESCRIPTION

A fully automatic, hydraulically operated trash compactor capable of displacing up to 54 cubic yards per hour. The refuse is compacted into metal containers which can be unloaded by either a front load or rear load trash truck. Detailed specifications can be found on the rear of this product sheet.

### MODEL SELECTION

There are five standard models in the series:

- **Model 520A** - the standard full-size trash compactor equipped with a 5 HP power unit for high volume applications.
- **Model 520ESII** - also a full-size trash compactor, provides an economical solution with a 1 HP power unit for smaller buildings.
- **Model 520SS** - is specially designed to fit into very small trash rooms where the shortest container packer is required.
- **Model 520T1** - a fully automatic, hydraulically operated trash compactor capable of displacing up to 24 cubic yards of trash per hour.
- **Model 520T5** - a fully automatic, hydraulically operated trash compactor capable of displacing up to 65 cubic yards of trash per hour.

### FEATURES

A photo-electronic sensor starts the compaction cycle when refuse enters the hopper and turns the machine off when the hopper is empty. The trash compactor automatically shuts off if an uncrushable object is encountered. An unload light is provided to signal a full container. A service access door is provided in the hopper, equipped with an electronically interlocked safety switch which prevents the machine from operating if the access door is open. An emergency stop button is provided for safety. An optional programmable logic controller is available.

**BUILT WITH PRIDE  
IN YORK, PA USA**

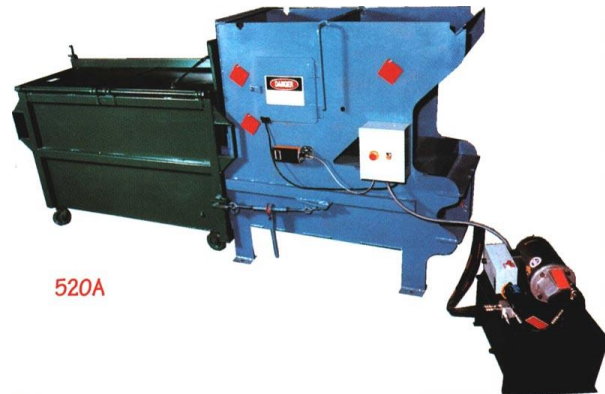

## SPECIFICATIONS

	520A	520ESII	520SS	520T1	520T5
Chamber Capacity	6.5 cf	6.5 cf	N/A	7.0 cf	8.0 cf
Compaction Force (M)	15,075 lbs	10,360 lbs	13,815 lbs	7,850 lbs	19,625 lbs
Top Opening Throat	24" L x 26" W	24" L x 26" W	23" L x 30" W	22" L x 30" W	26" L x 30" W
Ram Face Pressure (M)	32.8 psi	22.60 psi	14.5 psi	14.5 psi	36.3 psi
Volume Displacement	54.0 cy/hr	19.0 cy/hr	N/A	24.0 cy/hr	33.0 cy/hr
Cycle Time	16 seconds	44 seconds	60 seconds	57 seconds	17 seconds
Size, without container (L x W x H)	66 x 38 x 67 in	66 x 38 x 67 in	51 x 38 x 75 in	50 x 44 x 68 in	50 x 44 x 68 in
Weight, without container	1,650 lbs	1,500 lbs	950 lbs	1,450 lbs	1,550 lbs
Motor Power, AC, 60 Hz	208/230/460V, 3 ph, 4 wire	115/208/230V, 1 ph, 15 AMP	115/208/230V, 1 ph, 15 AMP	115/208/230V, 1 ph, 15 AMP	208/230/460V, 3 ph, 4 wire
Motor Horsepower	5 HP	1 HP	1 HP	1 HP	5 HP
Hydraulic Pump	1-Stage	1-Stage	1-Stage	1-Stage	1-Stage
Cylinder Bore Diameter	3"	3"	4"	(2) 2.5"	(2) 2.5"
Control System, Fused, AC	115V	115V	115V	115V	115V
Dimension "A" – Machine Length with Front Load Container	142"*	142"*	102"*	125"*	125"*
Dimension "B" – Room Length Minimum with Front Load Container	154"*	154"*	114"*	137"*	137"*

\*Note – for rear load container, subtract 7"

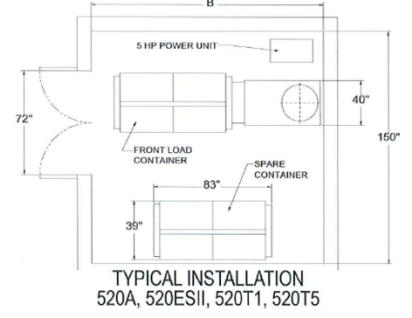
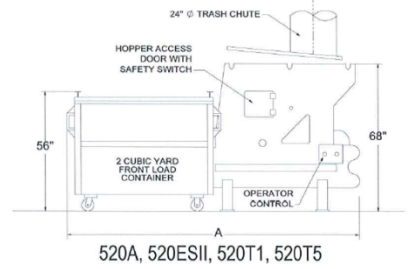
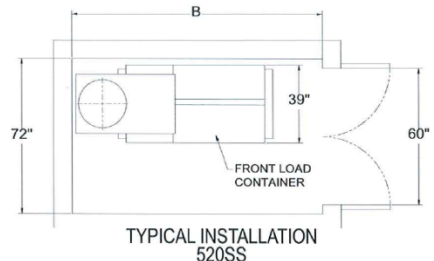
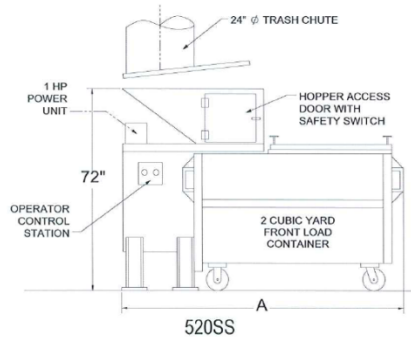

Due to continual product improvement PRECISION MACHINERY SYSTEMS reserves the right to change specifications without notice. The information and pictures used in the document are for illustrative purposes only.